

外形安装尺寸
Mounting Dimension Sheets-overview

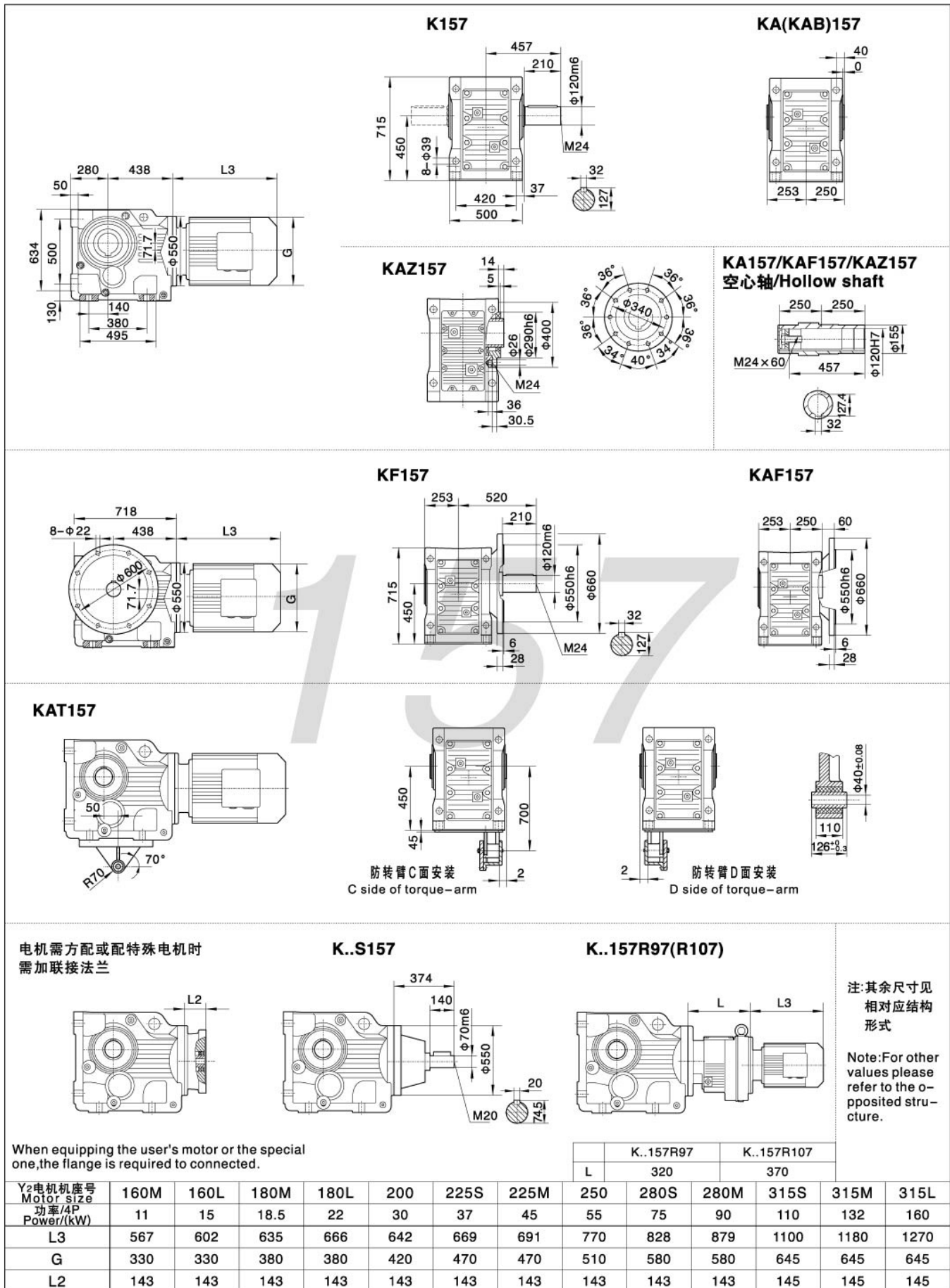

K